



COMPACT HOME CINEMA is an electric screen dedicated to the Home Theatre market and it is the right alternative to the Double Format or to the Compact Tensioned screens because high quality features mark it out from the other Home Theatre models.

A black drop on the top of the projection surface allows to install this screen inside false ceilings or inside rooms with high ceiling.

Side black borders let perceive a brighter and sharper image.

Available in 4:3, 16:9, 16:10 formats or customized sizes.



False ceiling trim kit
(optional - for details see p. 48)

White side covers
(optional)

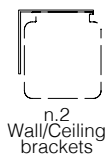
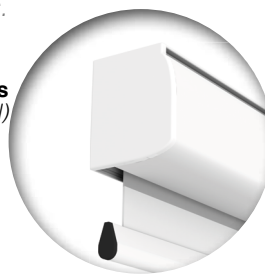

n.2
Wall/Ceiling
brackets



n.1
On/off
switcher

INCLUDED



RF Remote
control with
receiver
built-in motor

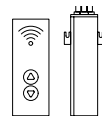

Kit RF Remote
control with
external
receiver



Interface
switch 12 volt



Low voltage
contact
interface



Faster and
quiet motor

OPTIONAL pag 62-63

**DROP OF
PROJECTION
CLOTH**
STANDARD

**FRONT DROP OF
PROJECTION
CLOTH**
(optional)

WALL-CEILING BRACKET

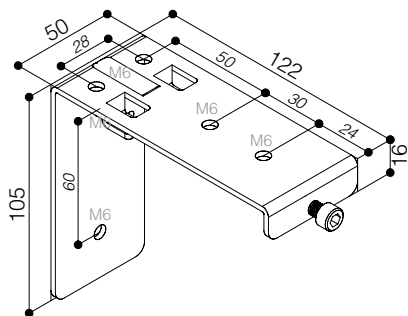

HOUSING DIMENSIONS

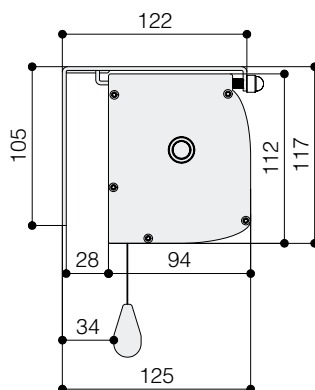

WALL MOUNTING

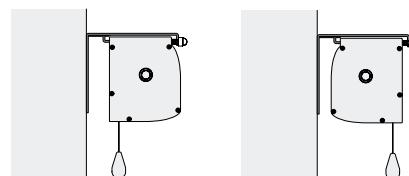

CEILING MOUNTING

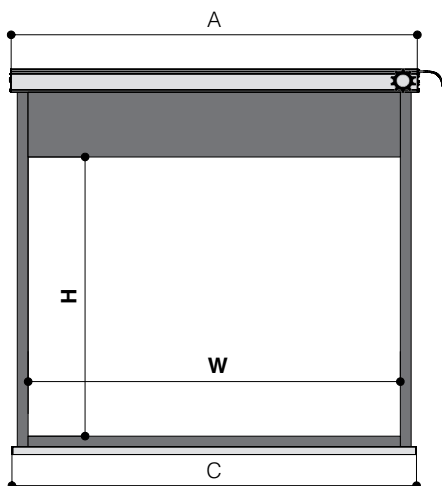
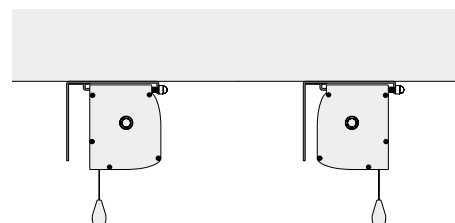

TECHNICAL SPECIFICATIONS

- Silent motor system provides a smooth and quiet operation
 - Power: **6 Nm**
 - Speed: **17 rpm**
 - Power supply: **230V / 50 Hz**
 - Consumption: **137 W**
 - Certification: **IMQ**
- Totally manufactured from aluminium
- Smart design and easy to install
- Housing dimensions: 94x112 mm. (DxH)
- Housing painted with white epoxy powders (RAL 9010)
- Two universal mounting brackets either for ceiling or for wall
- On/off switcher included
- Power cable located at the **right** side of the screen housing seen from the front
- Flame-retardant projection surfaces - classification M1 and B1
- Side black borders of 5 cm., black bottom border of 5 cm., black top drop of 30 cm. and black dowel bar: height 35 mm. - depth 20 mm.
- Screen housing available in different colours (optional)

DIMENSIONS measures in cm

4:3 Ratio Viewing area (WxH)	16:9 Ratio Viewing area (WxH)	16:10 Ratio Viewing area (WxH)	Overall dimensions A - C	Approx. net weight (Kg)
160 x 120	160 x 90	160 x 100	179 - 174	15
180 x 135	180 x 101	180 x 112	199 - 194	16
200 x 150	200 x 112	200 x 125	219 - 214	18
220 x 165	220 x 124	220 x 137	239 - 234	20
250 x 190	250 x 140	250 x 156	269 - 264	23
300 x 225	300 x 169	300 x 187	319 - 314	26

PROJECTION CLOTHS

Front projection surfaces	Gain		
White	1.2		
Matte White	1.2		
Lumi Grey	0.8		
Microperforated	1.1		
Lumi Grey Microperforated	0.8		
Cinesound*	0.7		
Fibre Matte*	1.25		
Hi-Light*	2.3		

*Limited in height

The measures in the drawings are expressed in millimetres.

Warranty: 5 years on the motor - 24 months on the other components





COMPACT TENSIONED is a motorized screen that incorporates a tab guide cable system which maintains horizontal tension to hold the screen surface perfectly flat.

This product has been specifically studied for the niche of the Home Theatre market.

This is the reason why it is the right solution for the most particular and demanding requests.

It is professionally masked with black light absorbing treatment for edge - to - edge pictures.

Available in 4:3, 16:9, 16:10 formats or customized sizes.



White side covers
(optional)

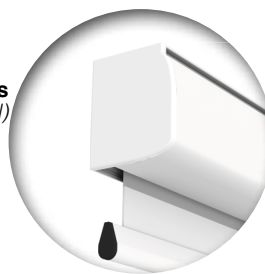

False ceiling trim kit
(optional - for details see p. 48)

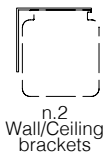

n.2
Wall/Ceiling
brackets



n.1
On/off
switcher



RF Remote
control with
receiver
built-in motor

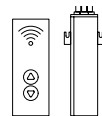

Kit RF Remote
control with
external
receiver



Interface
switch 12 volt



Low voltage
contact
interface



Faster and
quiet motor

INCLUDED

OPTIONAL pag 62-63

**DROP OF
PROJECTION
CLOTH**
STANDARD

**FRONT DROP OF
PROJECTION
CLOTH**
(optional)

WALL-CEILING BRACKET

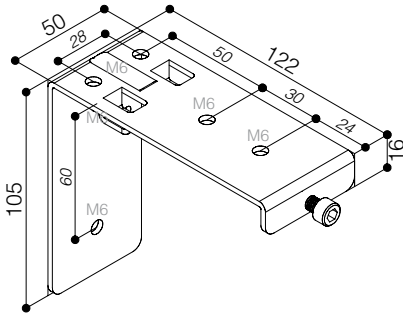

HOUSING DIMENSIONS

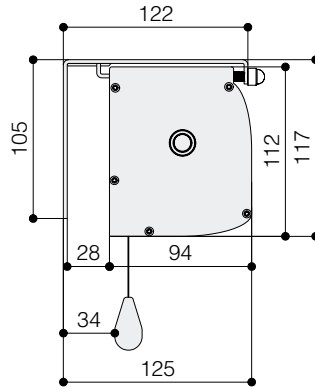

WALL MOUNTING

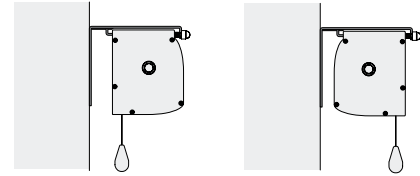

CEILING MOUNTING

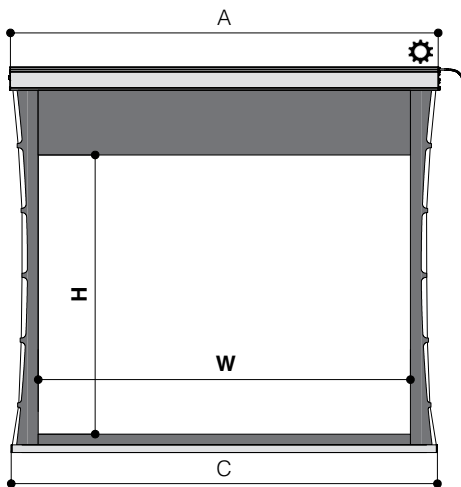
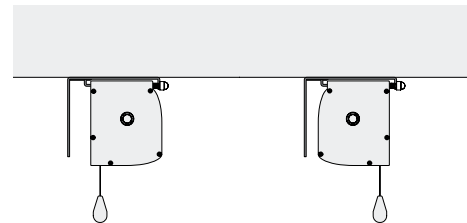

TECHNICAL SPECIFICATIONS

- Silent motor system provides a smooth and quiet operation
 - Power: **6 Nm**
 - Speed: **17 rpm**
 - Power supply: **230V / 50 Hz**
 - Consumption: **137 W**
 - Certification: **IMQ**
- Totally manufactured from aluminium
- Smart design and easy to install
- Housing dimensions: 94x112 mm. (DxH)
- Housing painted with white epoxy powders (RAL 9010)
- Two universal mounting brackets either for ceiling or for wall included
- On/off switcher included
- Power cable located at the **right** side of the screen housing seen from the front
- Flame-retardant projection surfaces - classification M1 and B1
- Side black borders of 5 cm. (in the narrowest point), black bottom border of 5 cm., black top drop of 30 cm. and black dowel bar: height 35 mm. depth 20 mm.
- Hour-shape glass tensioning system to provide perfect flatness
- Screen housing available in different colours (optional)

DIMENSIONS measures in cm

4:3 Ratio Viewing area (WxH)	16:9 Ratio Viewing area (WxH)	16:10 Ratio Viewing area (WxH)	Overall dimensions A - C	Approx. net weight (Kg)
160 x 120	160 x 90	160 x 100	198 - 194	15
180 x 135	180 x 101	180 x 112	218 - 214	17
200 x 150	200 x 112	200 x 125	238 - 234	19
220 x 165	220 x 124	220 x 137	258 - 254	20
250 x 190	250 x 140	250 x 156	288 - 284	22

PROJECTION CLOTHS

Front projection surfaces	Gain		
Matte White	1.2		
Lumi Grey	0.8		
Microperforated	1.1		
Lumi Grey Microperforated	0.8		
Cinesound*	0.7		
Bright Contrast 3D*	1.4		

*Limited in height

The measures in the drawings are expressed in millimetres.

Warranty: 5 years on the motor - 24 months on the other components

